



SVENSK PUMPSTYRNING AB
SÄKER STYRNING

SPS Pump Pit SPS-800-AV-S1 with Vortex Impeller Pump for Wastewater

“High-quality pump pit with long service life”



The SPS pump pit SPS-800-AV-S1 is a heavy-duty pump pit equipped with a vortex impeller pump and a brass check valve, designed for pumping wastewater before a treatment plant. It is also equipped with an SPS guide rail system for easier handling and removal of the pump.

Our pump pits are built with high quality and long service life.

The pump and discharge pipe are made of stainless steel and feature a convenient quick coupling for easy lifting in and out of the pit. Installation is simple thanks to the self-anchoring pump housing, and the rounded bottom design allows wastewater to flow more easily toward the pump without creating dead zones, enabling the pump to operate more efficiently.

The pump is controlled by the SPS pump control system. Start, stop, and alarm functions are managed by a control tube that detects the water level in the pit. The SPS controller is preconfigured at delivery for quick and easy installation. Start/stop and alarm levels can easily be adjusted afterwards if required. All models can be equipped with remote connectivity if desired. Through this system you can monitor total operating time, operating time per day/week/year, and alarm logs via a monitoring landing page.

Beskrivning

Specifications

- Diameter: 800 mm
- Height: 2200 mm
- Inlet: \varnothing 110 mm
- Outlet: \varnothing 40 mm
- Cover: Cast iron, class D400
- Telescopic section: Yes
- Pump: Pedrollo VXM 15/35-N
- Max lifting height: 14 m
- Max flow: 8.3 L/s
- Voltage: 1 \times 230 V
- Output (P2): 1.10 kW
- Rated current: 7.4 A
- Check valve: Yes
- Level control: SPS pump control system
- Alarm: Yes
- Data monitoring: Optional

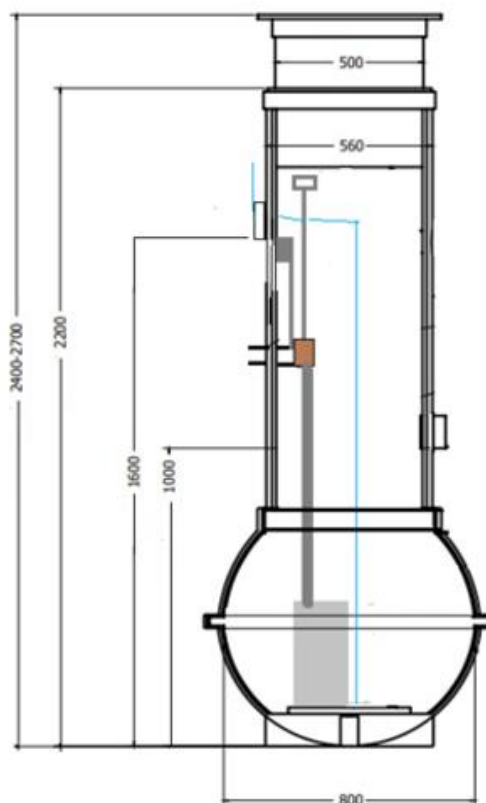

SVENSK PUMPSTYRNING AB
SÄKER STYRNING

www.svenskpsab.se